



WORK GRIPPER

Work Gripper AS series

Pneumatically operated stationary chuck Can be used as an alternative to a fixture



- Small and lightweight design, with inbuilt air cylinder
- Easy mounting by air piping
- Hollow structure optimal for bar workpiece and air blow
- Standard Soft Jaw for Power Chuck is used
- Lock valve unit ensures constant and regular gripping force in all machining conditions

* CE correspondence

Dimensional Drawings

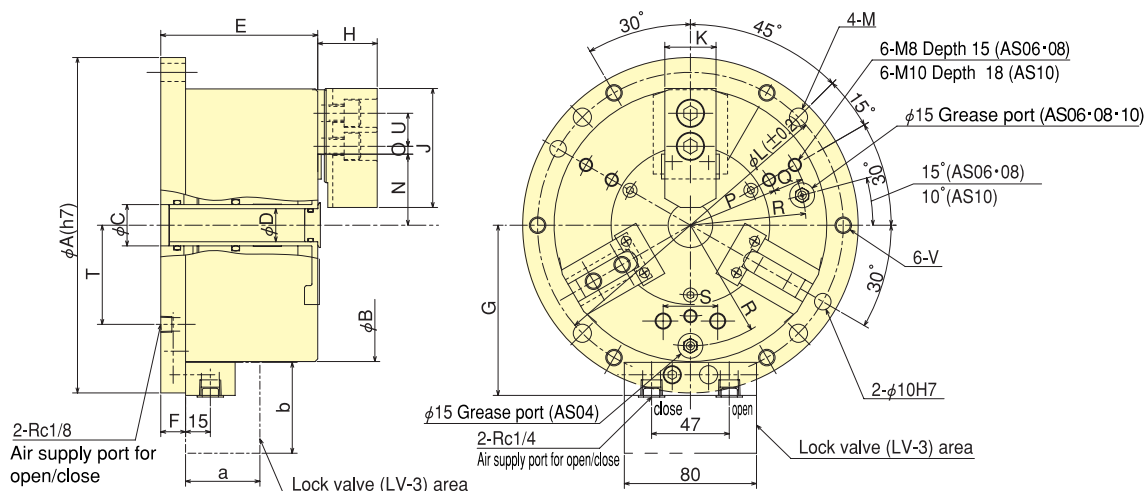

Dimensions

*The dimensions of a/b marked are the size of LV-3(Lock-valve).

Model	Dimensions	ϕA (h7)	ϕB	ϕC (H7)	ϕD	E	F	G	H	J	K	ϕL (± 0.2)	ϕM	N max.	N min.	O max.	O min.	P	Q	R
AS04		148	110	20H7	-	90	15	75.5	27	55	23	130	9	25.5	22.9	9.75	6.75	-	-	43
AS06		203	165	25H7	20	95	15	103	36	72	31	185	11	44.5	41.9	9.25	4.75	55	18	70
AS08		248	210	36H7	30	106	15	125.5	42	95	35	230	11	53	49.85	14.75	8.75	68	25	90
AS10		300	254	50H7	43	110	16	147.5	46	110	40	280	13	66	62.85	16	8.5	85	30	110

Model	Dimensions	S	T	U	V	a	b
AS04		33	34	14	M8	45	55
AS06		33	60.3	20	M10	45	55
AS08		33	80	25	M10	45	55
AS10		33	95	30	M12	45	55

Specifications

*Air Consumption = Under Pressure 0.6MPa Plunger Stroke per 10mm

Model	Specifications	Jaw Stroke (diameter) mm	Gripping force [Pneumatic at 0.6MPa (0.6kgf/cm ²)] kN (kgf)	Weight (kg)	Max. air pressure MPa(kgf/cm ²)	Matching soft jaw	Gripping diameter (mm)		Air consumption (Nℓ)
							Max.	Min.	
AS04		5.2	7.5 (765)	7.3	0.7 (7.0)	SB04B1	110	10	0.40
AS06		5.2	21.0 (2140)	16.0	0.7 (7.0)	SB06B1	165	23	1.04
AS08		6.3	33.0 (3365)	27.7	0.7 (7.0)	SB08B1	210	30	1.81
AS10		6.3	48.0 (4895)	42.5	0.7 (7.0)	SB10A1	254	50	2.52



WORK GRIPPER

Work Gripper (Multi-Plate)

AS.M.C series

Multi-plate allows simultaneous machining with up to six grippers on one plate



- Lock valve unit (option) can be mounted
- Three jaws (AS type) and two jaws (AT type) can be combined freely

MODEL NUMBER EXPLANATION

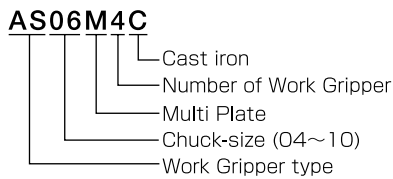

Dimensional Drawings

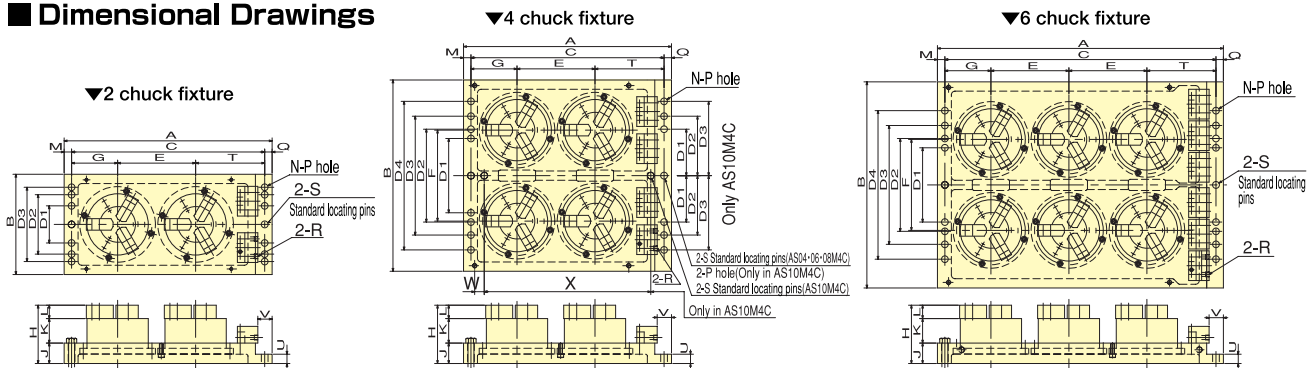

Dimensions

Model	Dimensions spec	Matching Work Gripper	A	B	C	D1	D2	D3	D4	E	F	G	H	J
AS04M2C	2 chuck fixture	AS04	450	205	410	100	160	-	-	155	-	100	143	55
AS06M2C	2 chuck fixture	AS06	560	270	520	100	160	200	-	210	-	124	157	55
AS08M2C	2 chuck fixture	AS08	655	315	615	160	200	250	-	255	-	150	174	55
AS10M2C	2 chuck fixture	AS10	765	375	725	160	200	250	-	310	-	175	182	60
AS04M4C	4 chuck fixture	AS04	450	380	410	160	200	250	320	155	180	100	143	55
AS06M4C	4 chuck fixture	AS06	560	515	520	200	250	320	400	210	245	124	157	55
AS08M4C	4 chuck fixture	AS08	655	600	615	200	250	400	500	255	285	150	174	55
AS10M4C	4 chuck fixture	AS10	765	705	725	160	200	250	-	310	335	175	182	60
AS04M6C	6 chuck fixture	AS04	660	380	620	160	200	250	320	155	180	155	143	55
AS06M6C	6 chuck fixture	AS06	770	555	730	200	250	320	400	210	245	124	157	55

Model	Dimensions	K	L	M	N	φP	Q	R	φS	T	U	V	W	X	Weight (kg)
AS04M2C		61	27	20	8	18	20	Rc1/4	18	155	25	38.5	-	-	17.0
AS06M2C		66	36	20	12	18	20	Rc1/4	18	186	25	38.5	-	-	26.0
AS08M2C		77	42	20	12	18	20	Rc1/4	18	210	25	38.5	-	-	32.0
AS10M2C		76	46	20	12	18	20	Rc1/4	18	240	25	43.5	-	-	50.0
AS04M4C		61	27	20	16	18	20	Rc1/4	18	155	25	38.5	-	-	31.0
AS06M4C		66	36	20	16	18	20	Rc1/4	18	186	25	38.5	-	-	47.0
AS08M4C		77	42	20	16	18	20	Rc1/4	18	210	25	38.5	-	-	58.0
AS10M4C		76	46	20	14	18	20	Rc1/4	18	240	25	43.5	40	645	90.0
AS04M6C		61	27	20	16	18	20	Rc1/4	18	155	25	38.5	-	-	40.0
AS06M6C		66	36	20	16	18	20	Rc1/4	18	186	25	38.5	-	-	67.0



WORK GRIPPER

2-Jaw Work Gripper

AT series

Secure gripping of all types of component
Can be used as an alternative to a fixture

- Small and lightweight design, with inbuilt air cylinder
- Easy mounting by air piping
- Hollow structure optimal for bar workpiece and air blow
- Standard Soft Jaw for Power Chuck is used
- Lock valve unit ensures constant and regular gripping force in all machining conditions

* CE correspondence



Dimensional Drawings

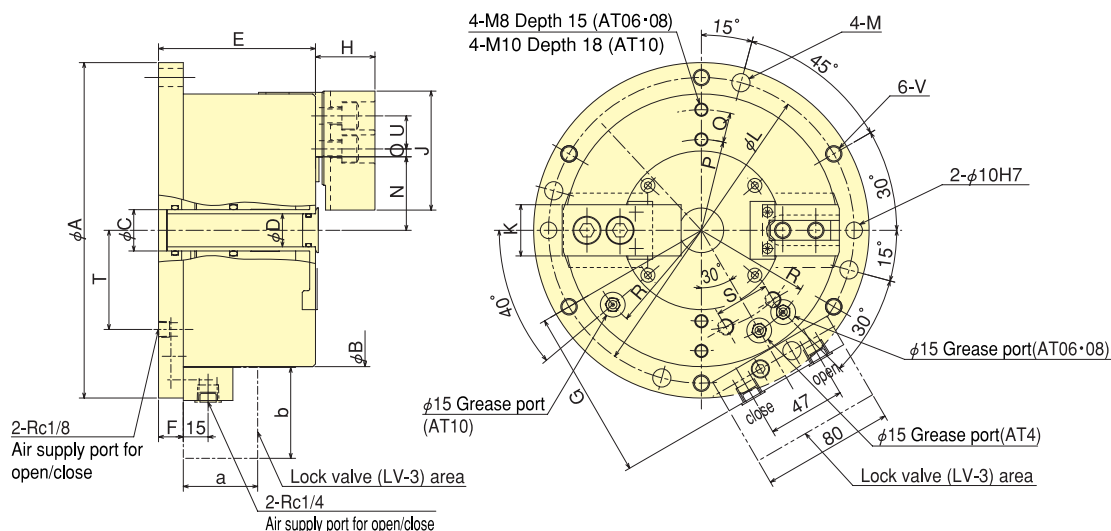

Dimensions

*The dimensions of W/X marked are the size of LV-3(Lock-valve).

Model	Dimensions	φA (H7)	φB	φC	φD	E	F	G	G	H	J	K	φL (±0.2)	φM	N max.	N min.	O max.	O min.	P	Q
AT04		148	110	20H7	-	90	15	75.5 (110.5)		27	55	23	130	9	25.5	22.9	9.75	6.75	-	-
AT06		203	165	25H7	20	95	15	103 (138)		36	72	31	185	11	44.5	41.9	9.25	4.75	55	18
AT08		248	210	36H7	30	106	15	125.5 (160.5)		42	95	35	230	11	53	49.85	14.75	8.75	68	25
AT10		300	254	50H7	43	110	16	147.5 (182.5)		46	110	40	280	13	66	62.85	16	8.5	85	30

Model	Dimensions	R	S	T	U	V	a	b
AT04		43	33	34	14	M8	45	55
AT06		70	33	60	20	M10	45	55
AT08		90	33	80	25	M10	45	55
AT10		110	33	95	30	M12	45	55

Specifications

*Air Consumption = Under Pressure 0.6MPa Plunger Stroke per 10mm

Model	Specifications	Jaw Stroke (diameter) mm	Gripping force [Pneumatic at 0.6MPa (0.6kgf/cm ²)] kN (kgf)	Weight (kg)	Max. air pressure MPa (kgf/cm ²)	Matching soft jaw	Gripping diameter (mm) Max.	Gripping diameter (mm) Min.	Air Consumption (Nℓ)
AT04		5.2	7.5 (765)	6.9	0.6 (6.0)	SB04A1T	110	10	0.40
AT06		5.2	21.0 (2140)	15.0	0.6 (6.0)	SB06A1T	165	23	1.04
AT08		6.3	33.0 (3365)	26.7	0.6 (6.0)	SB08A1T	210	30	1.81
AT10		6.3	48.0 (4895)	40.8	0.6 (6.0)	SB10A1T	254	50	2.52



WORK GRIPPER

2-Jaw Work Gripper (Multi-Plate) ATM.C series

Multi-plate allows simultaneous machining with up to six grippers on one plate

- Lock valve unit (option) can be mounted
- Three jaws (AS type) and two jaws (AT type) can be combined freely

MODEL NUMBER EXPLANATION

AT06M4C

- Cast iron
- Number of Work Gripper
- Multi Plate
- Chuck-size (04~10)
- Work Gripper type

Dimensional Drawings

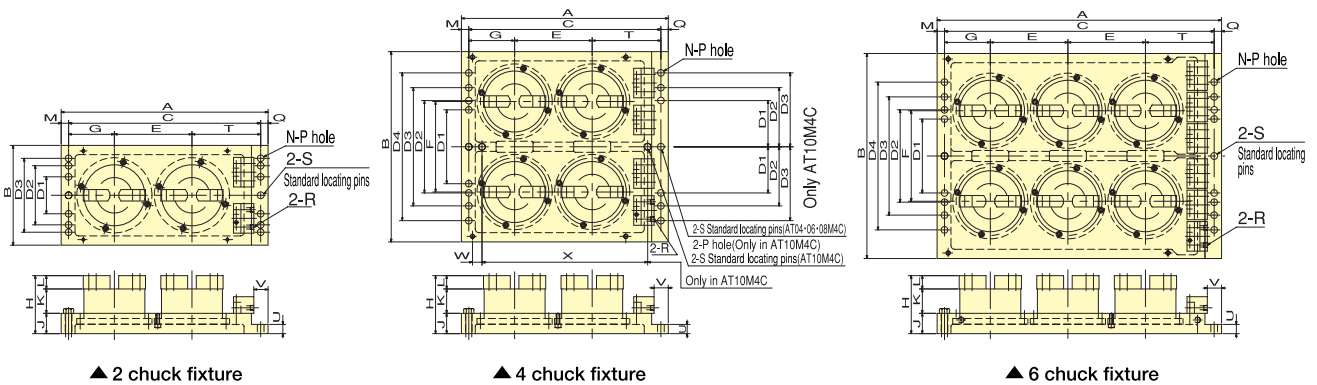

Dimensions

Model	Dimensions		Matching Work Gripper	A	B	C	D1	D2	D3	D4	E	F	G	H	J
	spec														
AT04M2C	2 chuck fixture		AT04	450	205	410	100	160	-	-	155	-	100	143	55
AT06M2C	2 chuck fixture		AT06	560	270	520	100	160	200	-	210	-	124	157	55
AT08M2C	2 chuck fixture		AT08	655	315	615	160	200	250	-	255	-	150	174	55
AT10M2C	2 chuck fixture		AT10	765	375	725	160	200	250	-	310	-	175	182	60
AT04M4C	4 chuck fixture		AT04	450	380	410	160	200	250	320	155	180	100	143	55
AT06M4C	4 chuck fixture		AT06	560	515	520	200	250	320	400	210	245	124	157	55
AT08M4C	4 chuck fixture		AT08	655	600	615	200	250	400	500	255	285	150	174	55
AT10M4C	4 chuck fixture		AT10	765	705	725	160	200	250	-	310	335	175	182	60
AT04M6C	6 chuck fixture		AT04	660	380	620	160	200	250	320	155	180	155	143	55
AT06M6C	6 chuck fixture		AT06	770	555	730	200	250	320	400	210	245	124	157	55

Model	Dimensions													Weight (kg)
	K	L	M	N	φP	Q	R	φS	T	U	V	W	X	
AT04M2C	61	27	20	8	18	20	Rc1/4	18	155	25	38.5	-	-	17.0
AT06M2C	66	36	20	12	18	20	Rc1/4	18	186	25	38.5	-	-	26.0
AT08M2C	77	42	20	12	18	20	Rc1/4	18	210	25	38.5	-	-	32.0
AT10M2C	76	46	20	12	18	20	Rc1/4	18	240	25	43.5	-	-	.050
AT04M4C	61	27	20	16	18	20	Rc1/4	18	155	25	38.5	-	-	31.0
AT06M4C	66	36	20	16	18	20	Rc1/4	18	186	25	38.5	-	-	47.0
AT08M4C	77	42	20	16	18	20	Rc1/4	18	210	25	38.5	-	-	58.0
AT10M4C	76	46	20	14	18	20	Rc1/4	18	240	25	43.5	40	645	90.0
AT04M6C	61	27	20	16	18	20	Rc1/4	18	155	25	38.5	-	-	40.0
AT06M6C	66	36	20	16	18	20	Rc1/4	18	186	25	38.5	-	-	67.0



WORK GRIPPER

Pull Lock Work Gripper PLS series

Pull Lock for steady gripping
Stable cutting is guaranteed through the high precision and exceptional gripping performance. Can be used as alternative to a fixture



- Stable cutting is performed by high precision and high gripping force
 - Perfect for CNC machining applications, thanks to component detection feature
 - Multiplate system also accommodates PLS Series gripper, allowing up to six grippers per station
 - It's compact design, featuring an inbuilt cylinder allows for more space in the machining envelope
- * CE correspondence

Dimensional Drawings

PLS06, PLS08

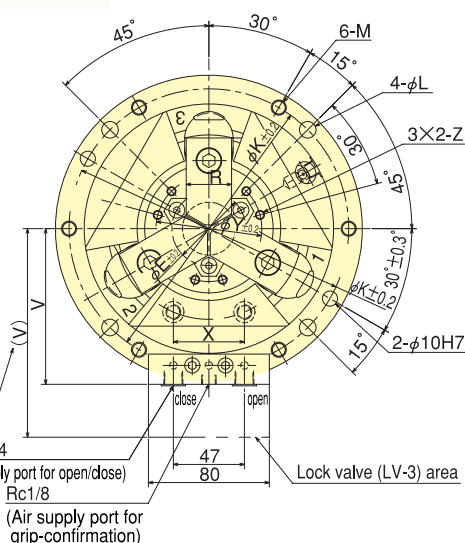
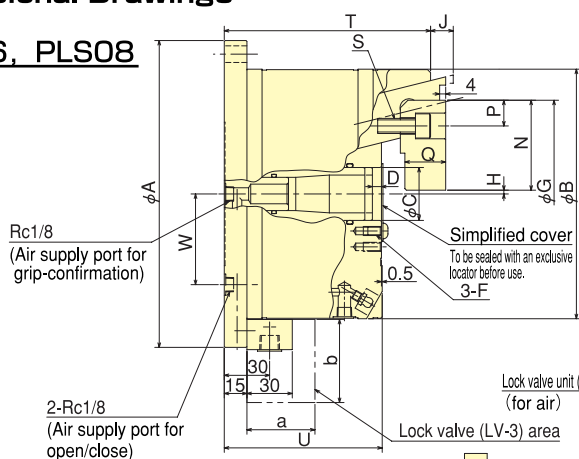

PLS04

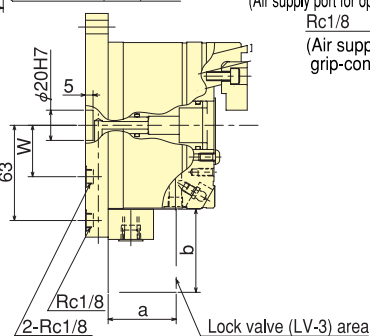

Dimensions *The dimensions of a/b marked are the size of LV-3(Lock-valve).

Dimensions Model	A (h7)	B (0.0/-0.1)	C (0.01/0)	D min.	E	F	G (H6)	H max.	H min.	H max.	H min.	K (±0.2)	L	M	N
PLS04	148	110.1	32	4.5	42	M5×10	84	2.25	0.75	7	1	130	9	M 8	40.5
PLS06	203	165.1	35	6.0	49	M6×12	124	3.75	1.25	15	5	185	11	M10	59.5
PLS08	248	210.1	55	6.0	71	M6×12	154	3.75	1.25	17	7	230	11	M10	74.5

Dimensions Model	P	Q	R	S	T	U	V	(V)	W	X	Y	Z	a	b
PLS04	9.5	14	20	M 6	103	85.5	75.5	110.5	34	33	62	M5×10	45	55
PLS06	17	27	30	M10	136.5	104.5	103	138	60	47	70	M6×12	45	55
PLS08	20.5	31	35	M12	155.5	118.5	125.5	160.5	80	47	95	M6×12	45	55

Specifications *Clamping force varies in clamping state for jaws and workpiece. *Air Consumption = Under Pressure 0.6MPa Plunger Stroke per 10mm

Specifications Model	Plunger stroke mm	Jaw stroke (diameter) mm	Gripping force kN (kgf)				Max. allowable pressure MPa (kgf/cm ²)		Min. allowable pressure MPa (kgf/cm ²)	Gripping diameter mm		Weight (with standard soft jaw) kg	Air Consumption (N ℓ)
			Pneumatic at 0.6MPa (6kgf/cm ²)		Hydraulic at 1.3MPa (13kgf/cm ²)		Pneumatic	Hydraulic		Max.	Min.		
PLS04	6	3	6.7 (683)	7.4 (754)	16.0 (1631)	17.4 (1774)				φ60	φ4	7.4	0.22
PLS06	10	5	18.5 (1886)	22.0 (2243)	40.0 (4078)	45.0 (4588)	0.7 (7.0)	1.3 (13.0)	0.2 (2.0)	φ100	φ7	18.0	0.54
PLS08	10	5	37.0 (3772)	40.0 (4078)	80.0 (8157)	84.0 (8565)				φ130	φ7	33.0	0.93



WORK GRIPPER

Jig Module JM200

Securely grips a wide range of irregularly shaped components
New clamping system accommodates a variety of workpieces

- Option of lock valve mechanism meaning that during machining work can be held without air line
- Centralizing or compensating is switchable
- Face grip (end grip) is possible
- Seating can be checked automatically



One unit is equipped with three gripping functions.

Centralizing Grip Centralizing

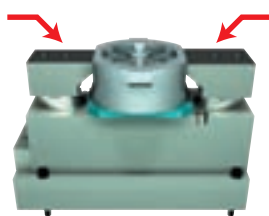

External gripping by pull down

Center compensation grip Compensating

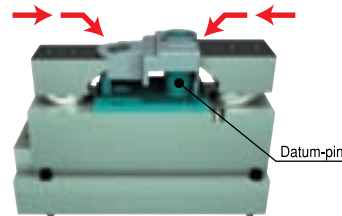

Compensating gripping using pin locators and pull down

End face grip Face Grip

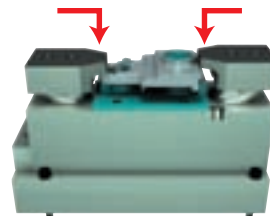

Face gripping by pull down

Seating can be checked

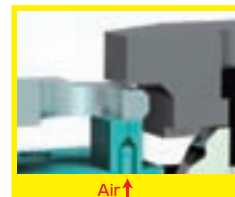

Dimensional Drawings

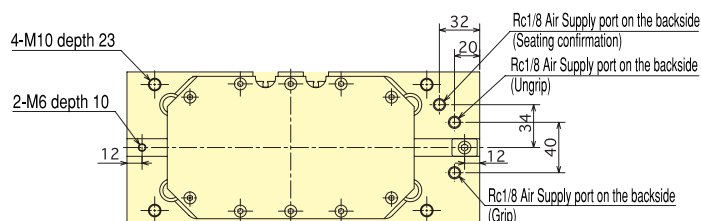
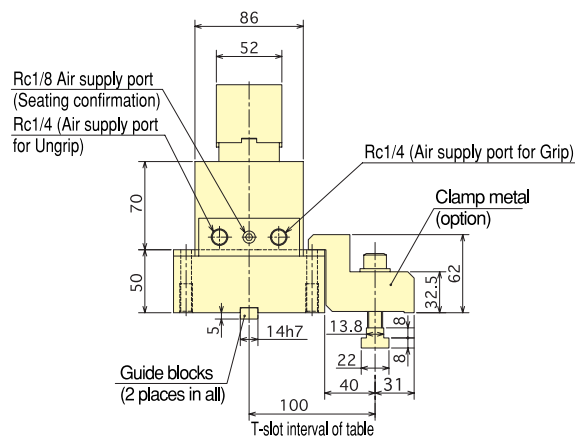
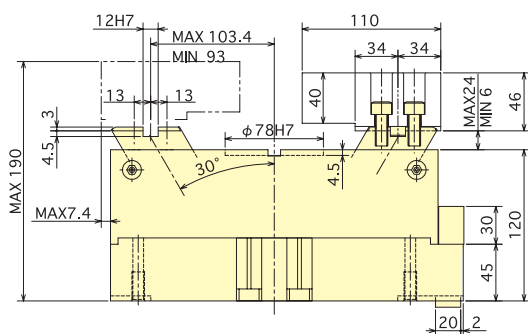
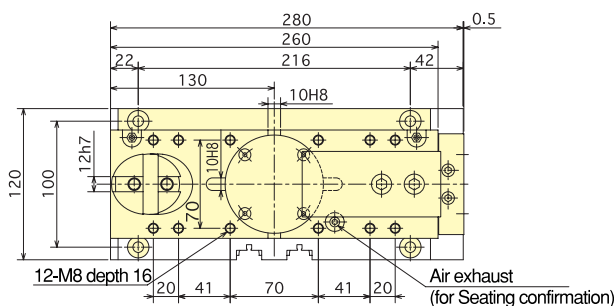

Note : Grip metals for mounting main part can be optionally offered.

Specifications

Cylinder stroke (mm)	Jaw stroke (mm)		Max. Gripping force kN (kgf)		Min. Gripping force kN (kgf)		Max. Oscillating amount (mm)		Work size (mm)		Weight (kg)	Max. air pressure MPa (kgf/cm ²)	Max. air pressure MPa (kgf/cm ²)
	Centering/Compensation	Face grip	Centering/Compensation	Face grip	Centering/Compensation	Face grip	Centering/Compensation	Face grip	Centering/Compensation	Face grip			
18	20.8	18	9.0(918)	5.5(561)	3.0(306)	1.8(184)	1.5	2.5	40~200	40~150	19.0	0.6(6.0)	0.2(2.0)



WORK GRIPPER

Stationary Scroll Chuck SC-S series

**Durable, reliable and versatile
Stationary scroll chuck**



- Available on multiplate for easy fixture mounting
- Compact designed
- Soft jaw can be machined to adapt to a wide range of machine workpieces
- Uses exclusive handle for clamping

Dimensional Drawings

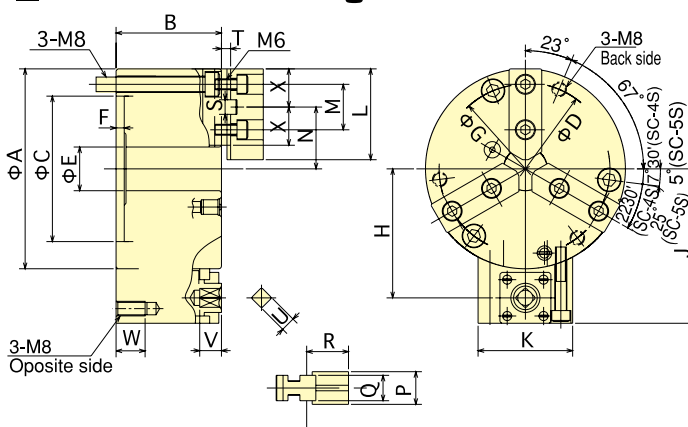
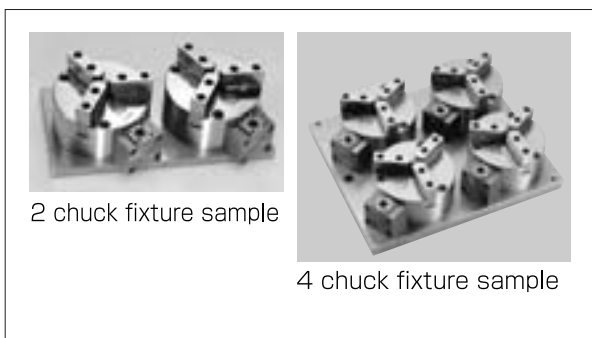

Specifications

Model	Specifications	Max. Gripping force kN (kgf)	Allowable handle torque N·m (kgf·m)	Weight (kg)	Gripping range	
					External mm	Internal mm
SC-4S		9.6 (979)	27.5 (2.8)	4.0	3~95	29~84
SC-5S		12.0 (1224)	39.2 (4.0)	5.3	3~110	33~100

Dimensions

Model	Dimensions																						
	A	B	C (H6)	D	E	F	G	H	J	K	L	M	Nmin	Nmax	P	Q	R	S	T	U	V	W	X
SC-4S	110	58	80	95	24	4.5	93	71	85	52	50	25	26	37	18	14	23	8	5	8	12	16	21
SC-5S	130	60	100	115	32	4.5	113	81	95	56	60	30	30	45	20	16	26	8	6	8	12	16	25

Dimensional Drawings for Soft Jaw

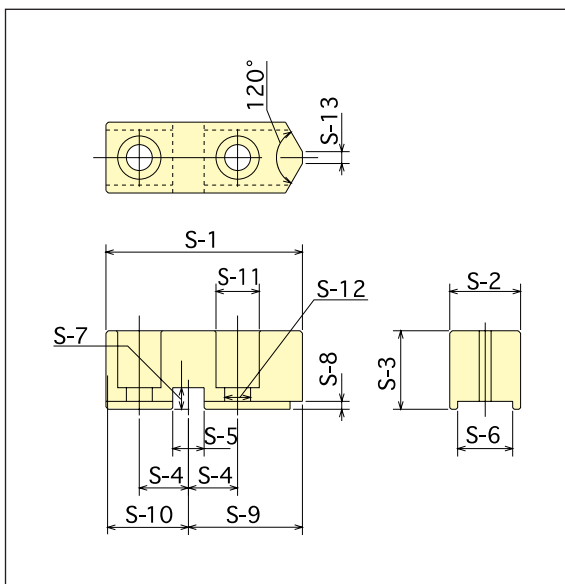

Dimensions for Soft Jaws

Model	Dimensions	chuck size	S-1	S-2	S-3	S-4 ±0.1	S-5 +0.01	S-6 +0.05 +0.02
SBS05S	5	60	20	22	15	8	16	

Model	Dimensions						
	S-7	S-8	S-9	S-10	S-11	S-12	S-13
SBS04S	5.5	2	29	21	11	6.6	3
SBS05S	5.5	2	35	25	11	6.6	3

Dimensional Drawings for Handle

Dimensions for Handles

Model	Dimensions						
	a	b	c	d	e	f	g
SC-4S	130	60	17	120	8	10	11
SC-5S	150	60	20	130	10	12	11

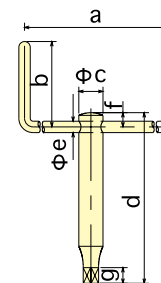



WORK GRIPPER

Option

LV-3

■ Air Lock Valve Unit

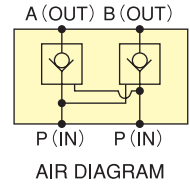
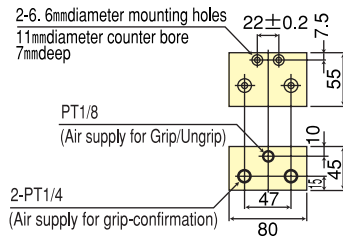

AV-02F

■ Original manual air valve by **KITAGAWA**



AV-02F allows air system to be simplified

※Valves can be easily mounted onto work gripper and multiplate.

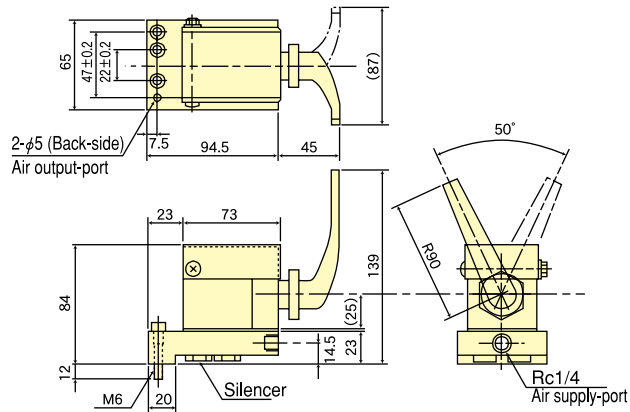

■ Mounting Drawing (by AV-02F)

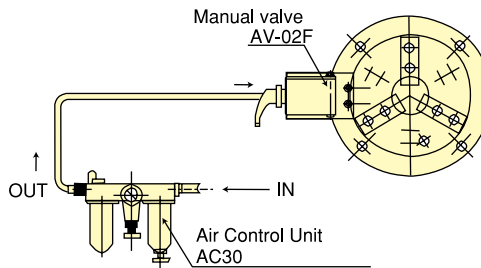

Max. pressure	1MPa (10kgf/cm ²)
Lever movement	50°
Connection port	Rc ¹ / ₄

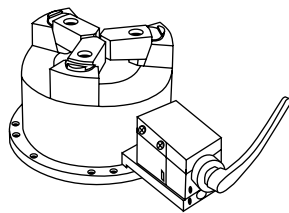

VH-201

■ Manual Air Valve



Max. pressure	1MPa (10kgf/cm ²)
Lever movement	90°
Connection port	Rc ¹ / ₄

■ Mounting Drawing (by VH-201)

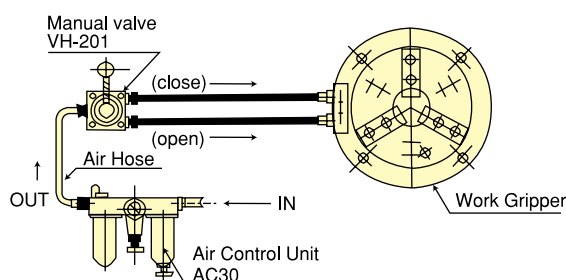

AC30

■ Air Control Unit (With Lubrication)

Max. pressure	1MPa (10kgf/cm ²)
pressure setting range	0.05~0.85MPa (0.5~8.6kgf/cm ²)
Filter mesh	5μm
Max. temperature	60°C
Connection port	Rc ¹ / ₄